

# MV-MD3-DC

Retail mini dome camera's



Our discreet 500TVL mini domes are the ideal low-cost solution for retail applications. They can be easily mounted on the wall or the ceiling and can be supplied with an optional quick install pipe that reduces installation time to a minimum.



MV-MD3-DC

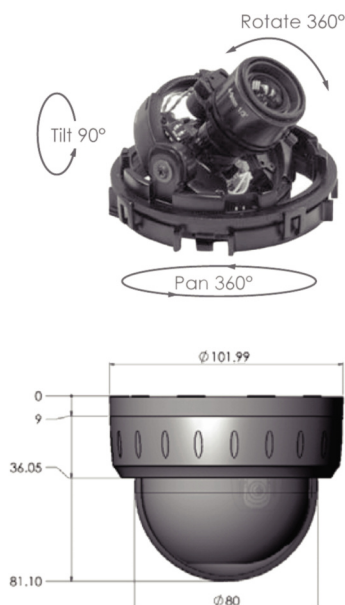

Unit: mm

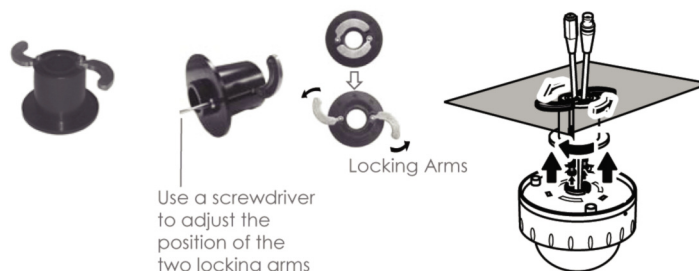

## Features

- 3" mini Dome
- Resolution: 500TVL
- Sony SS11X DSP
- 1/3" Format CCD
- 4~9mm DC iris lens
- 1.2 Lux @ F1.6
- 3-axis gimbal
- Operates on 12vDC
- Quick install pipe (Optional)

## General Specifications

Material	UV stable polycarbonate for base, shoud and bubble (Cleae bubble with liner).
Bubble	Elongated bubble to support 90 degree rotation
Gimbal	3-axis gimbal
Fixing	Surface mount Supports direct mount to US single gang box mount Duppots direct mount to UK metal electrical box
Lens	4-9mm F1.6 AI/VR lens
Resolution	500VK with basic 2 dip function
Image size	1/3" Interline CCD sensor 752H x 582V pixels
DSP	Sony SS11X
Sensitivity	1.2 Lux @F1.6
Voltage	DC 12V(10 ~ 20V) or AC24V(20 ~ 28V)
Operation Temperature	-10°C ~ +55°C
Storage Temperature	-20°C ~ +70°C

## Lens Specifications

Type of Focal	Varifocal, 4.0~9.0mm
Type of Iris	DC Drive Auto-Iris
Iris Range	F1.6 ~ 360
Field of View	Diagonal: 92.8°~39.4° Horizontal: 71.0°~31.6° Vertical: 51.6°~23.6°
Minimum Object Distance	0.15m
Lens Type	Aspherical

## Quick Install Kit MD-QIP (Optional)

Installer friendly.  
Universal ceiling/wall mount.  
Reduces installation time to a minimum.

AVE (Europe, London)  
Endeavour House,  
Coopers End Road,  
Stansted,  
Essex, CM24 1SJ

Tel: +44 (0)845 600 9323  
Fax: +44 (0)845 600 9363  
Email: [avesales@ave-uk.com](mailto:avesales@ave-uk.com)  
Web: [www.ave-uk.com](http://www.ave-uk.com)

AVE (Europe, Dublin)  
123 Millennium Business Park  
Ballycoolin  
Dublin 11  
Rep. Of Ireland

Tel: +353 (1) 8647450  
Fax: +353 (1)8647451  
Email: [avesales@ave-europe.eu](mailto:avesales@ave-europe.eu)  
Web: [www.ave-europe.eu](http://www.ave-europe.eu)

AVE (USA, Texas)  
2501 Central Parkway, Suite C1  
Houston,  
Texas TX 77092

Tel: 281-443-2300  
Fax: 281-443-8915  
Email: [sales@aveusa.com](mailto:sales@aveusa.com)  
Web: [www.aveusa.com](http://www.aveusa.com)